

E-THROTTLE FOR BMW S 1000 RR (K67) 2019-



BMW Motorrad
Motorsport
Official Partner



LIMITATIONS OF USE

- This E-throttle control must be used only on BMW S 1000 RR (K67) 2019-, use on other vehicles isn't permitted.
- Use of this product is strictly limited to Racing and official competitions on closed roads or tarmac tracks.
- All different uses aren't permitted by Domino.
- Offroad use is strictly prohibited. Any modification on E-throttle and his components is permitted.

ASSEMBLY INSTRUCTIONS

- This E-throttle must be assembled on the vehicle by a qualified operator, to assure the right product application.
- DOMINO s.r.l. isn't responsible for any consequence arisen from an incorrect product assembly, in particular where this activity is not certified by a skilled operator.
- All assembly operations shall be carried out with the battery not connected to main harness.
- NOTE: by installing/changing the throttle grip you have to re-do the adaptations (e.g. by using the M RCK software)
- Insert the E-throttle on the right handlebar.
- Fit the correct position in order to avoid any contact with handlebar end weight (minimum free play of 3mm is requested), brake master cylinder, etc.
- Tighten both screws at 3Nm torque.
- Fix the handlebar end weight at correct torque (see BMW prescription).
- Insert the rubber grip on throttle tube and fix firmly the grip by glue or iron wire, according to his producer instructions.
- Check free rotation and return to the initial position of throttle tube.
- Connect the 6 ways connector of the E-throttle to the corresponding connector on the main harness. Don't connect to other connectors. Fix the throttle cable in order to avoid possible contacts with hot or moving parts. Connect the battery to the main harness.
- Check procedure: switch-on the engine, in neutral gear.
- Turn and release the throttle without help: throttle shall come back to initial position by itself.
- Try to rotate the handlebar and check that the bike does not pick up.
- If the throttle control does not work properly, redo the check procedure once again, or anyway do not use the bike.
- With the bike raised on a bike stand, check the function of the E-throttle control.
- Only in case of positive checks, start to use on road the E-throttle control at low speed, increasing progressively the speed and checking the control of speed.

MAINTENANCE INSTRUCTIONS

- Clean regularly (depending on the use) the external parts of the throttle control by mild or car soaps.
- Use of high pressure water jets, abrasives, lubricants, solvents or degreasing products on all surfaces of the throttle is prohibited.
- In case of crashes, accidents or simply bike falls, send the E-throttle to Domino for a functional check, even if the product looks as not damaged

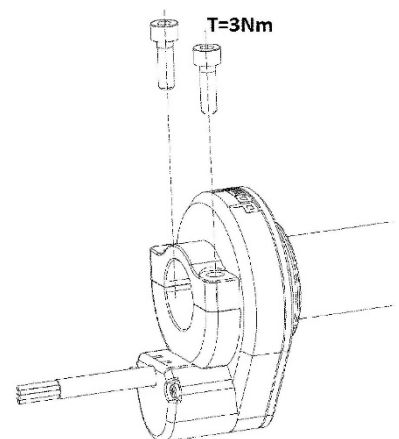
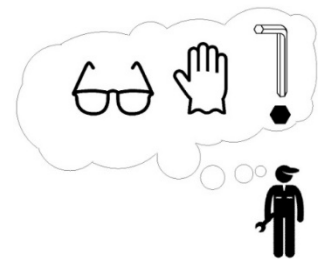

alpha Racing GmbH & Co. KG
Kronstaudener Weg 1
83071 Stephanskirchen
Tel. +49 (0) 80 36 / 30 313 -0
Fax +49 (0) 80 36 / 30 313 -199
info@alpharacing.com
www.alpharacing.com

COMPETENCE IN RACING